

R/C Throttle

for
LocoNet and XPressNet



R/C Throttle in original size



BaseUnit standard version (above)
with external antennas (below)



Now even better. The R/C Throttle is still to only device without limitations on XPressNet (XBus, Lenz) - and LocoNet (Digitrax, Uhlenbrock). Especially owners of the Intellibox can use special features with the R/C Throttle.

The R/C Throttle uses the well known DECT standard for data transmission, proved in millions of cordless phones. Good to know, when the R/C Throttle controls expensive models. So the throttle provides complete wireless operation offering flexibility and freedom when operating DCC controlled model trains.

One base station can handle up to four R/C Throttles making the system suitable for larger layouts as well.

Due to the extensive capabilities offered by the R/C Throttle, a wide variety of operational control and functionality is provided. To ensure that this capability is not intimidating, a special "Child" mode is available. This allows them to use the R/C Throttle without however having access to the advanced capabilities.

Since the R/C Throttle uses proven DECT-Technology, it is superior as far as security, range and speed is concerned. Now available with function F1 to F28 and some new features in the software.

Capabilities

[L] = LocoNet [X] = XPressNet

- backlight display
- operate and drive loco
- 5 fast storages for loco address
- stack for loco address
- light and functions F1-F28 **! new !**
- consist
- control of switches
- switch routes BaseUnit
- [L] dispatch and acquire locos
- programming in 'Ops Mode' (prog. on the main)
- apply and remove power from track
- emergency stop (complete system or loco)
- automatic powerdown
- "child" operation (all functions disabled, only the loco can be controlled)
- DECT radio controll
- range up to 300m (900 ft) outside, up to 100m (300 ft) inside
- digital system LocoNet (Digitrax, Uhlenbrock) and XPressNet (Lenz) – automatic detection
- [X] only one device-id for all throttles
- power for R/C Throttle 2x AA batteries (alkaline or rechargeable)
- BaseUnit with USB-interface
- software-update by customer
- Windows-Software to program the switch routes

Technology

One base station can handle up to four R/C Throttles. Several base stations can be connected to one central station. The maximum number of R/C Throttles is determined by the particular central station that is being used.

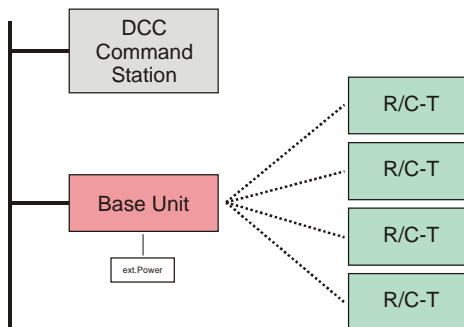

The antennas are internal in the standard version of the BaseUnit. To increase the range, the BaseUnit can be equipped with 2 external antennas (see pictures on previous side). This conversion can be done later.

Power: *	R/C Throttle	2 AA-Batteries
	BaseUnit	12V AC or DC 750mA
Dimensions:	R/C Throttle	120 x 65 x 22 mm
(L x W x H)	BaseUnit	120 x 65 x 40 mm 120 x 65 x 155mm **

* not included

** with external antennas

Idee

The idea to develop this R/C Throttle came from my desire to own a wireless control unit that provided the ultimate in functionality, capability and ease of operation on my garden railway.

Based on numerous requests from other hobbyists, I manufacture a very limited number of these units on a "Non-Profit" basis. The prices shown for these units simply cover my costs; there is no additional profit margin built into the price.

I made an EMC test in a test laboratory with the devices.

Prices (valid of 28.february 2010)

R/C Throttle:	SFr. 350.00	€ 225.00
BaseUnit standard:	SFr. 310.00	€ 200.00
BaseUnit with ext.antennas:	SFr. 410.00	€ 265.00

Delivery in Switzerland: the VAT cannot be shown separately.

Delivery outside of Switzerland: the VAT valid in the foreign country becomes additionally due.

The supply is effected from Switzerland and postage is not contained in the above prices. For orders from Germany a german bank account exists.

Order

In order to be able to hold the price despite risen costs, the R/C Throttle is predominantly produced with professional enterprises for electronic devices. Since for an economical production a minimum number of items must be manufactured, the R/C Throttle is produced per lot.

The R/C Throttle is available on stock. I receive gladly your order. You receive then a conformation of order, on which you pay 50% of the end price in the sense of a pre-payment. After receipt of this pre-payment the order is valid and I will send the R/C Throttle immediately. The second part of the amount becomes due then.

Contact

Matthias Manhart
Eichweid 45,
CH-8312 Winterberg
Switzerland
Phone: +41 (0)52 345 30 65
Homepage: www.beathis.ch
Email: matthias.manhart@gmx.net

All used registered trade marks and registered marks are property of the respective owners.